

DO . . . . .

Use a stringer to string the bow *each time*.

Figure 1: How to use a stringer

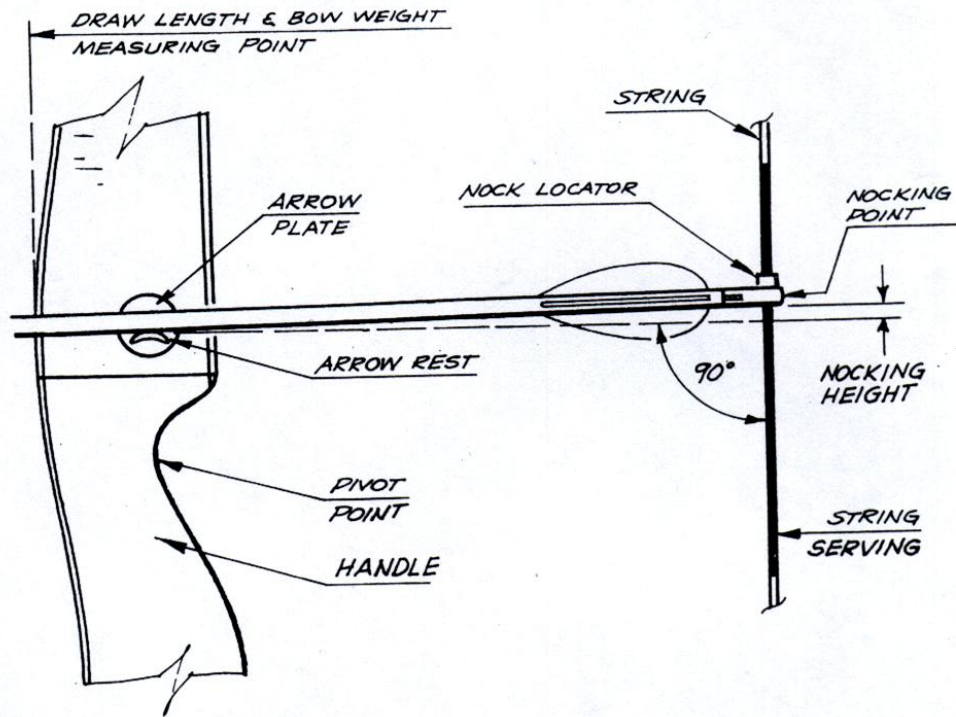

Figure 2: Recurve Equipment Labelling

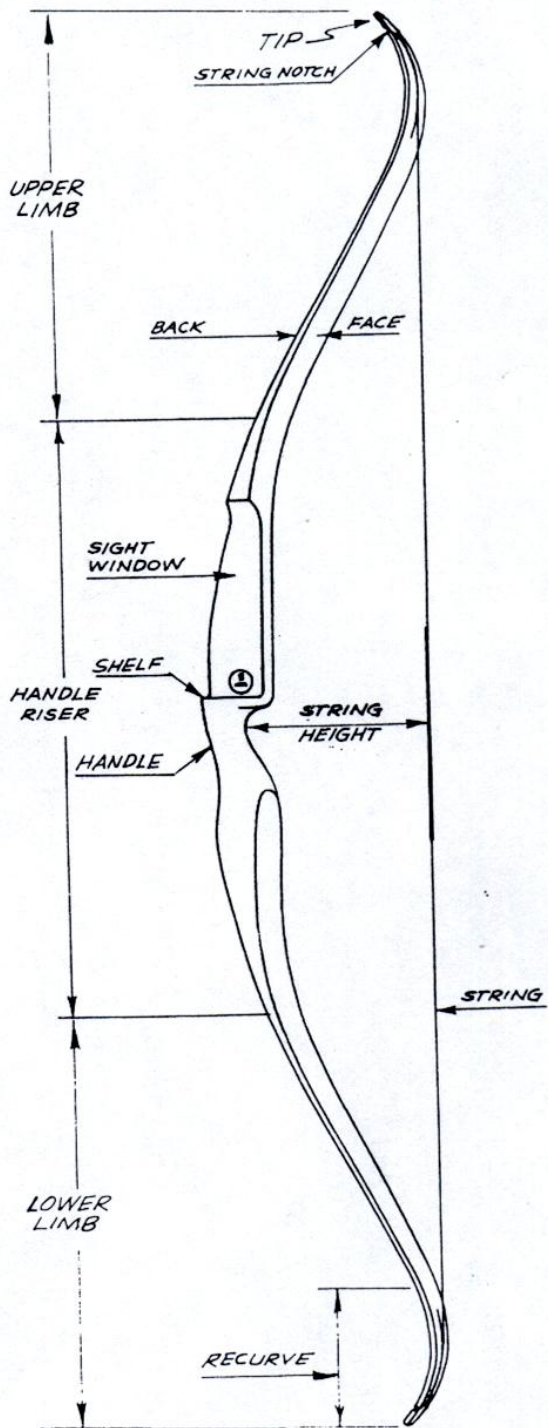

Figure 3: Recurve Equipment Labelling

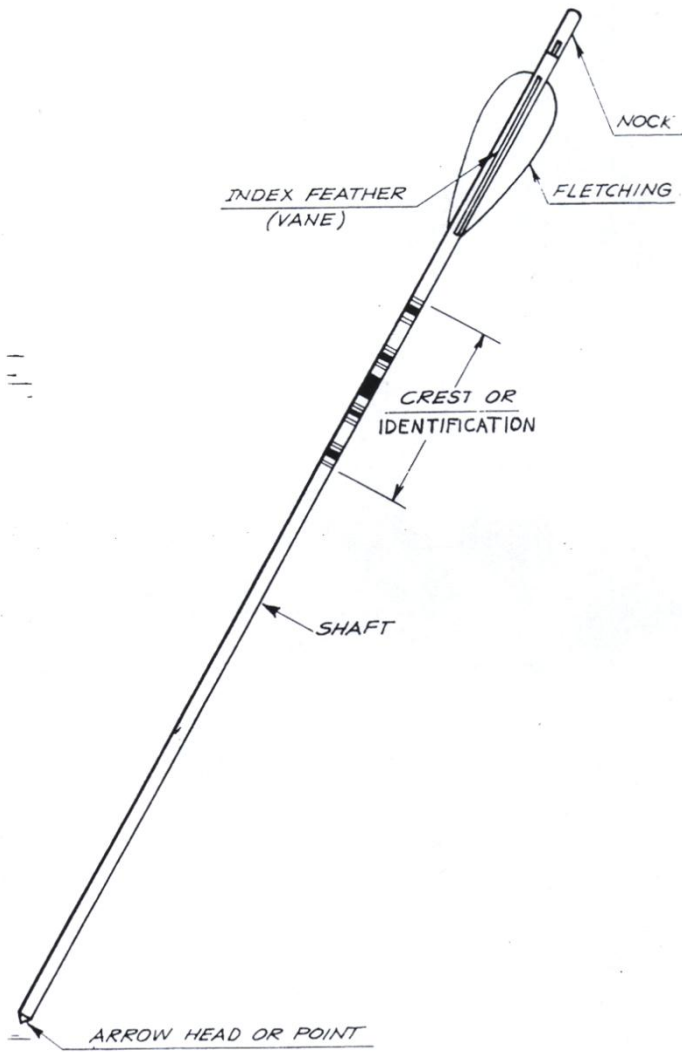
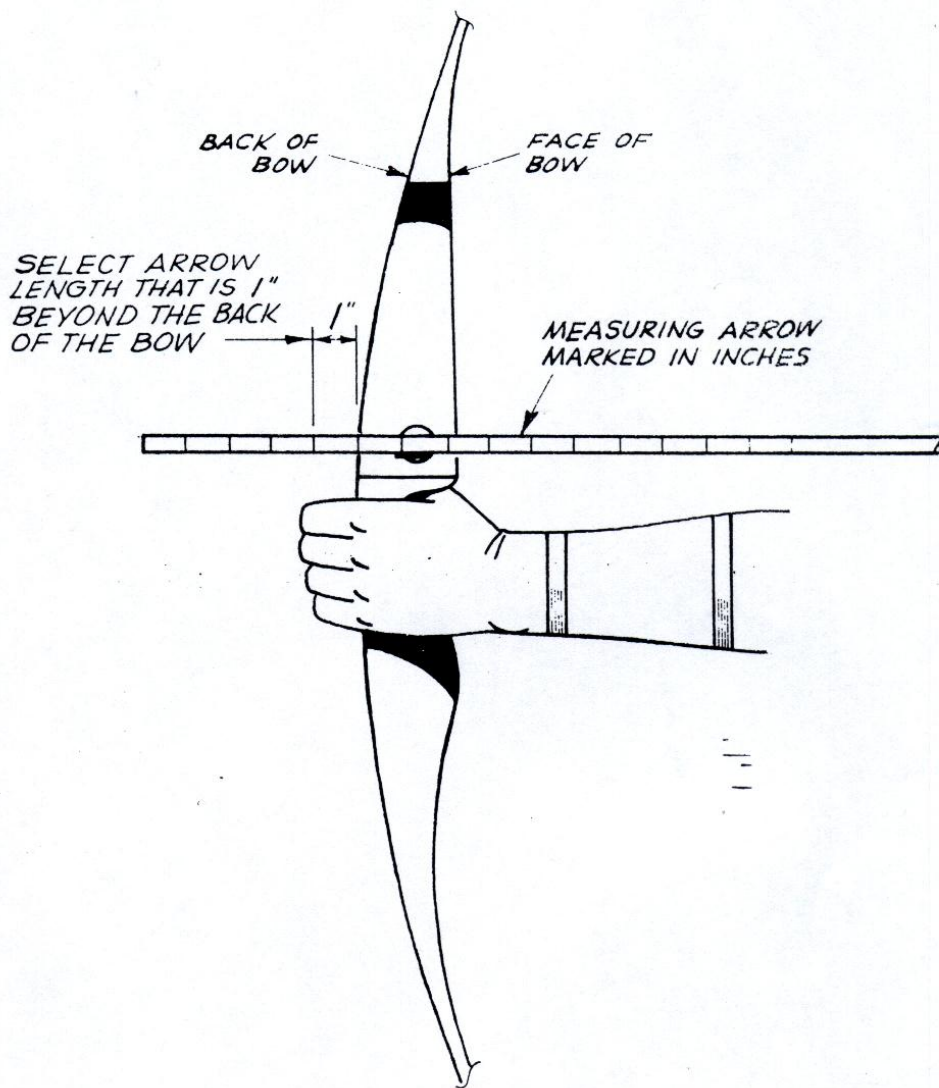

Figure 4: Arrow Labelling



DO . . . .

Be sure the arrows are long enough.

Figure 5: Arrow Measurement - note 2" recommended for beignners

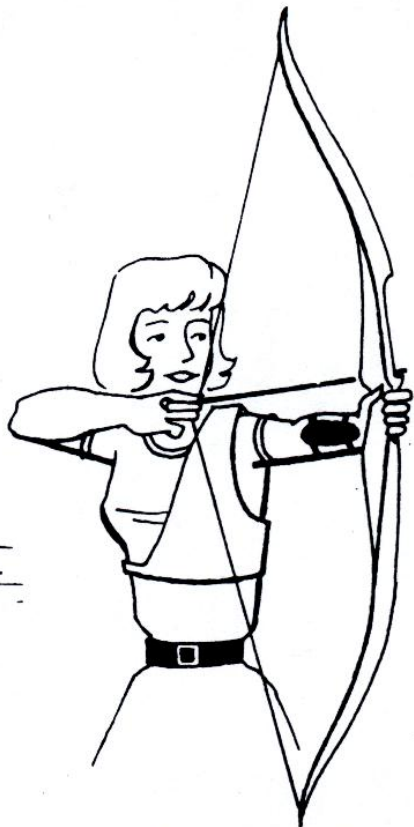

CLOTHING SHIELD

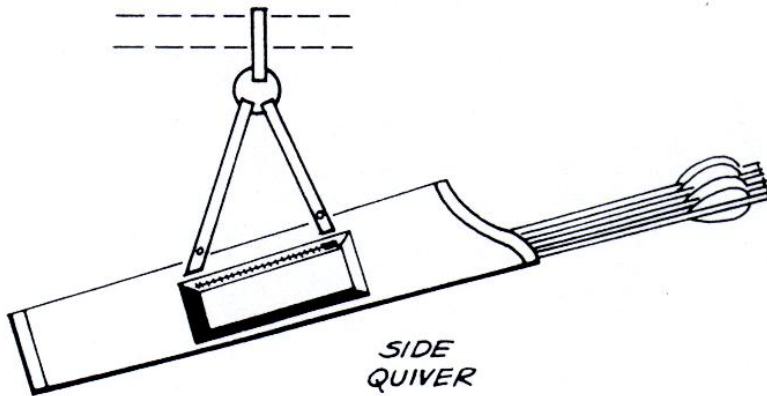

SIDE  
QUIVER

Figure 6: Chest Guard and Quiver

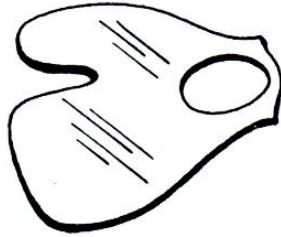

**FINGER TAB**

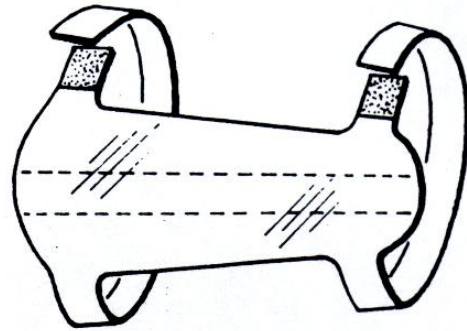

**ARM GUARD**

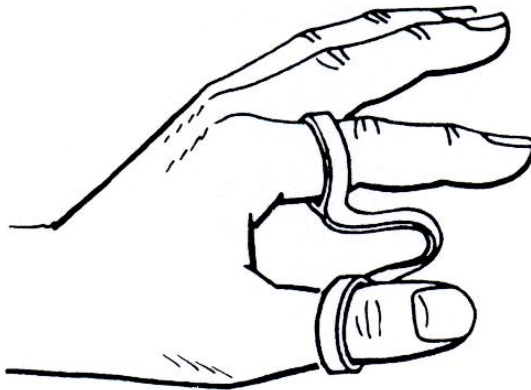

**FINGER SLING**

Figure 7: Finger Tab, Arm Guard and Finger Sling

# SAFETY



DO . . . .

Stay behind the shooting line while shooting is in progress.

Figure 8: Picking up an arrow when it drops



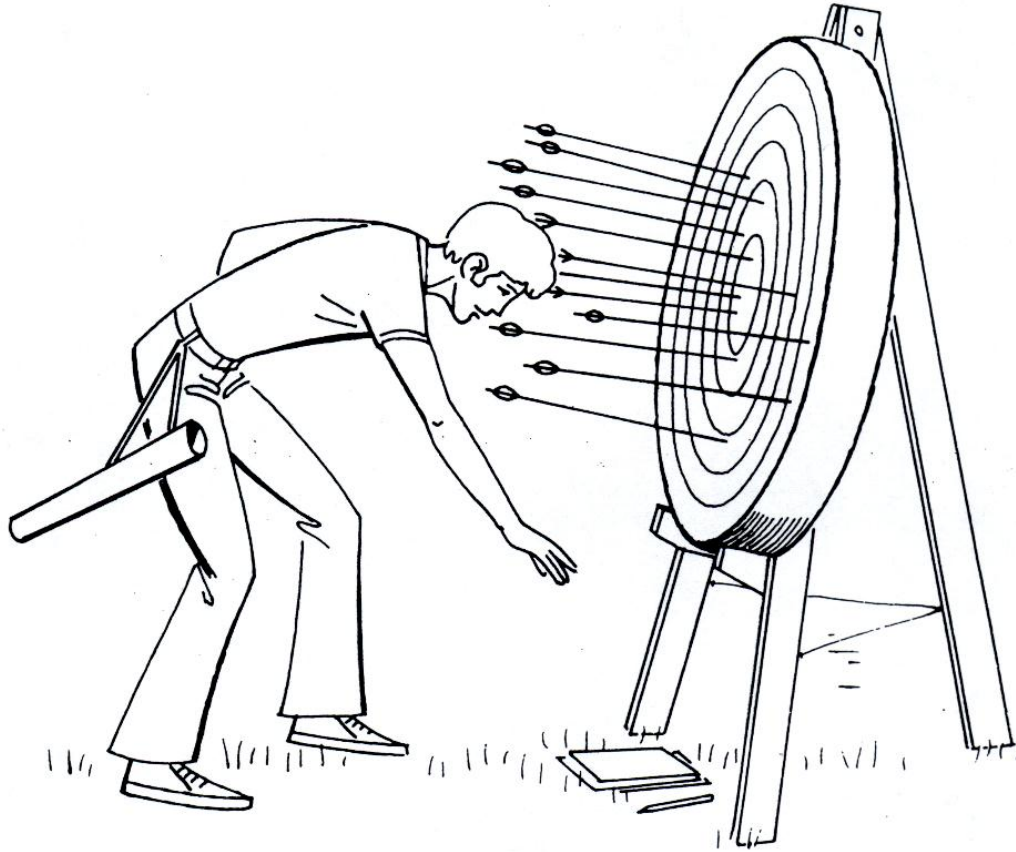

**DO NOT . . . .**

**Stand too close to the target when picking up score sheets.**

Figure 9: Dangers of picking up score sheets

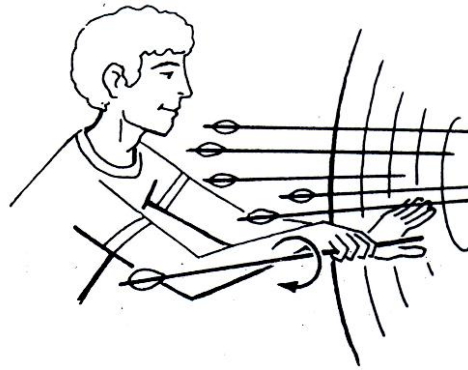

DO . . . . .

Remove arrows by bracing the target with one hand, twisting arrow with the other.

Figure 10: Method for pulling arrows